

SPECIFICATIONS FOR MECHNICAL FLOAT DRAIN MODEL EAD416

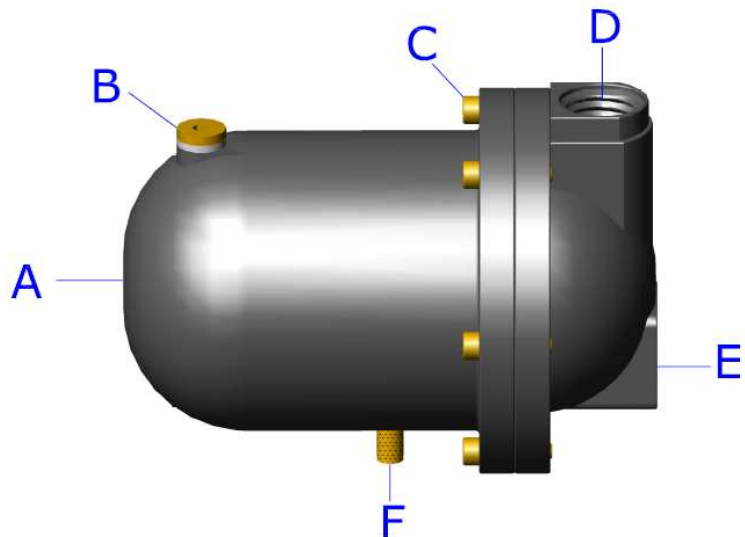

Standard Assembly

- A** - Housing
- B** - Breather Port
- C** - Allen Key Screws
- D** - Inlet Port
- E** - Outlet Port
- F** - Manual Discharge Valve



Features

- Complete assembly ready to install
- Automatic discharge of condensate
- Robust and corrosion free housing
- Zero operating cost, with no electricity required
- Little maintenance required and no regular replacement part

Breather Port Size:	Female 1/8" BSP
Inlet Port Size:	Female 1/2" BSP
Outlet Port Size :	Female 1/2" BSP
Max Pressure:	16 bar g
Body Material:	Die Cast Aluminum
Seal Ring Material:	NBR
Max. Temperature:	80°C
Open time:	Depends on amount of condensate in the system
Close time:	Depends on amount of condensate in the system
Voltage available:	Not applicable