



**HEATED
COMPRESSED
AIR ADSORPTION
DRYERS**

VEHDD SERIES

HEATED COMPRESSED AIR ADSORPTION DRYERS VEHDD SERIES

The Simple Philosophy of Heated Desiccant Dryers for Compressed Air

Drying compressed air through adsorption represents a purely physical process in the course of which water vapour is bound to the drying medium (desiccant) through binding forces of molecular adhesion. For adsorption to take place, moist air is directed through the adsorber at various operating pressures. During this process, the moist compressed air comes into contact with the hydrophilic desiccant molecules when it flows from the bottom to the top of the vessel. The desiccant molecules will retain the moisture which results in dry compressed air leaving the vessel.

How does the AFE VEHDD Desiccant Dryer work? Externally Heated Vacuum Dryer - Loop System

Two vessels connected in parallel are required for the continuous operation of drying via the adsorption process. Each vessel is filled with desiccants which act as the drying medium. AFE heated desiccant dryers use high performance silica gels which have a long service life at high input temperatures, resulting in very low pressure dew points.

The advantage of a vacuum system compared to other heated systems is the lower evaporation temperature. Under vacuum, water evaporates at a lower temperature when compared to under pressure. This saves heating time and therefore, more cost effective in terms of energy saving.

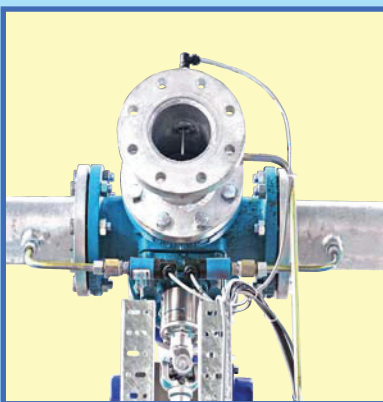

Stage 1: The moisture in the compressed air is absorbed by the silica gels in vessel A. Simultaneously desorption or re-generation in vessel B will occur under atmospheric conditions. This desorption process is assisted by triggering a vacuum pump which suck ambient air through a heater in a counter-current flow direction to the adsorption process. Once a specified re-generation temperature is reached, the thermostat will induce the heater to switch off

while the vacuum pump continues to suck ambient air to cool down the desiccant bed. As a safety feature, the system is equipped with a limiter which cuts off the heater in case of over-heating.



Stage 2: Upon completion of the heating cycle, the cooling phase of the desiccant begins. During this phase, the vacuum pump will continue to run and the heater is cut off. The cooling system is a loop system where the hot air is directed to a water cooler which cools down the desiccant bed and re-directed back to the cooler again. This repetitive cycle is temperature controlled and once the cooling temperature is achieved, the vacuum pump is automatically switched off. This loop system of cooling ensures that there will be no pre-loading of moisture from ambient air to the desiccant bed and thus, maintains a constant dew point.

Stage 3: To prepare the system for a change over, Vessel B is re-pressurized. Upon completion of re-pressurization, the system is now ready for a change over. The compressed air from vessel A will purge out and the drying cycle switches to vessel B. The entire process will repeat itself to continuously dry the compressed air.

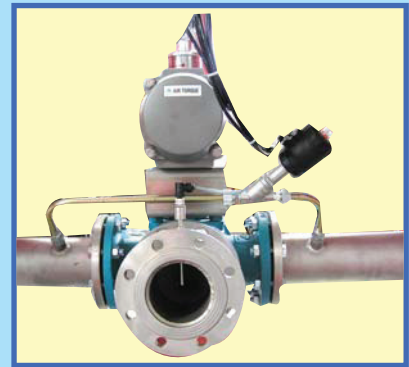

AFE offers different options of heated desiccant dryers and this include the vacuum heated system. As a standard, all VEHDD series dryers are equipped with a load control system (LCS) to maximize the adsorption time and minimize the re-generation time for cost effectiveness and energy saving operations. VEHDD series desiccant dryers are equipped with control system which include monitoring of inlet and outlet temperature and flow as well as operating parameter like pressure, temperature and dew point. The VEHDD series desiccant dryers include operation with either a 4/2 way valve combination or with single butterfly valves.

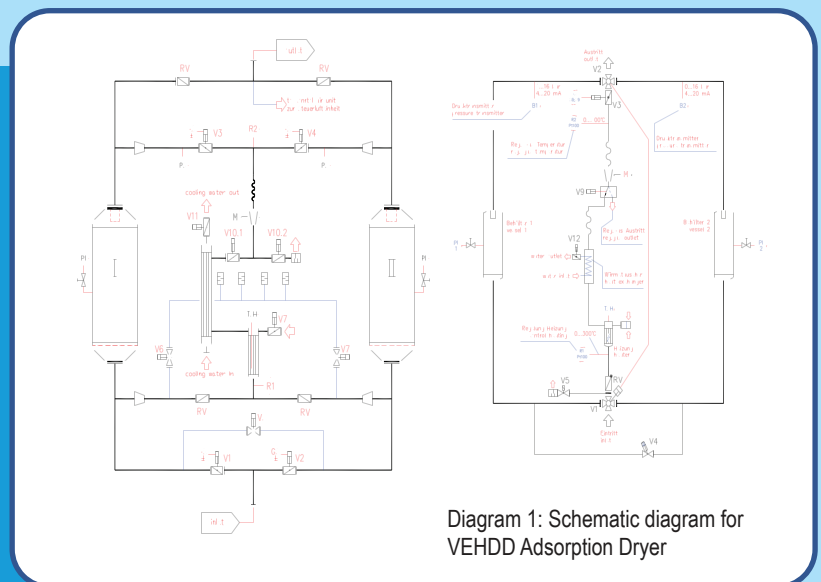
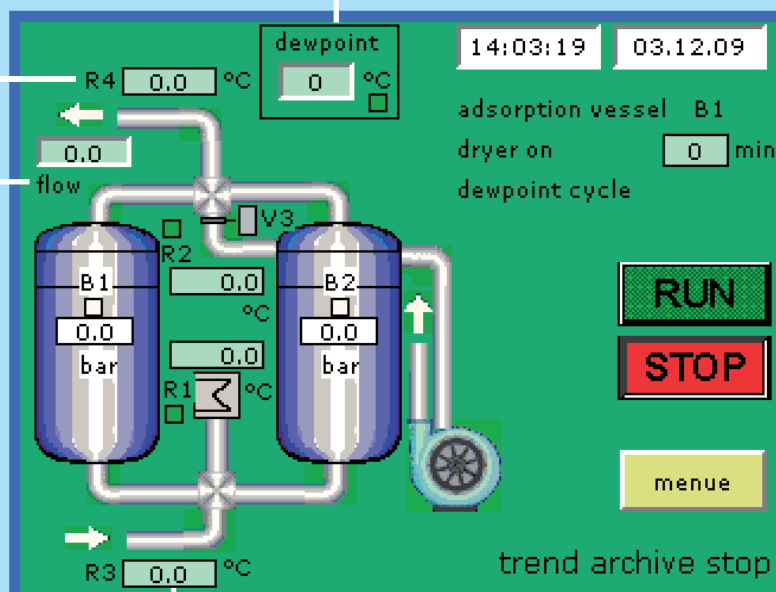

Diagram 1: Schematic diagram for VEHDD Adsorption Dryer

Features and Advantages of the VEHDD Series Dessiccant Dryers

- The welded vessels are designed according to ASME VIII Div1. Standards. (other designs and approvals on request)
- The stainless steel wedge wire in the wet area is a self cleaning system which allows an even distribution of air flow with low differential pressure across the system.
- Touch Screen controller for continuous monitoring, option for communication with customer control system via Profibus, Modbus build in.
- Monitoring of inlet and outlet temperature build in.
- Flow meter build in as standard.
- As standard equipped with Load Control System (LCS).
- AFE VEHDD Series Desiccant Dryers use high performance silica gel which is suitable for application in a wide range of operating conditions.
- Usage of standard industrial valves which are readily available and easily maintained.
- Low energy consumption, quick ROI.
- No purge is needed for cooling, 100% in, 100% out.
- Customized dryers according to OEMs' requirements are available upon request.



The VEHDD Series of Desiccant Dryers manufactured by AFE benefit from a simple but effective design which has been studied and improved with many years of experience in the compressed air industry. AFE dryers are manufactured to cater to a wide range of applications and the main benefits are:

- PROVEN TECHNOLOGY
- ROBUST CONSTRUCTION
- RELIABLE PERFORMANCE
- EASY MAINTENANCE
- NO PURGE, ZERO AIR LOSS

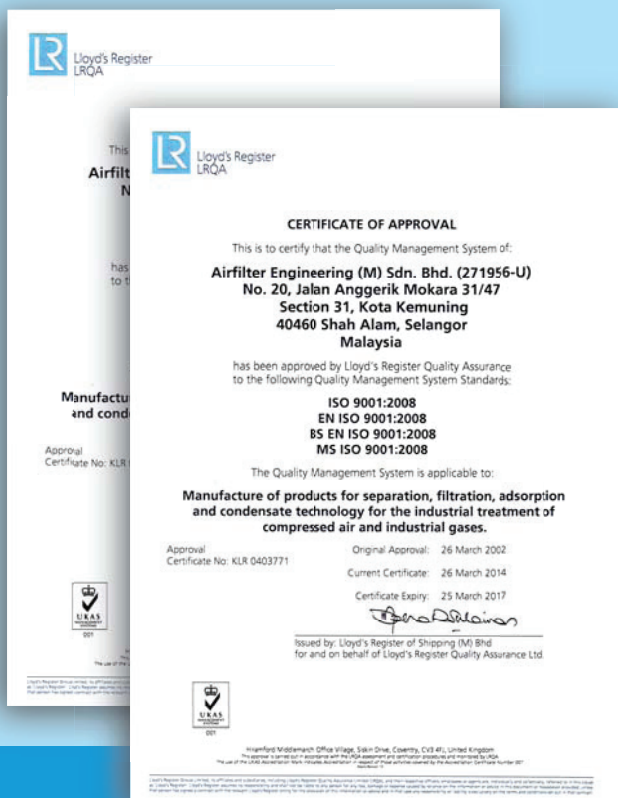

AFE manufactured desiccant dryers are fully tested and are in compliance with the ISO9001 quality system.

HEATED COMPRESSED AIR ADSORPTION DRYER VEHDD-SERIES DATA

VEHDD-SERIES HEATED COMPRESSED AIR ADSORPTION DRYER - SPECIFICATIONS

Model Number	Volume Flow Rate ¹				Dimensions (mm)			Connection	Weight	Power
	l/s	m ³ /min	m ³ /hr	cfm	A (D)	B (W)	C (H)	DN	kg	kW
VEHDD222	222	13.33	800	470	1099	1368	2160	DN50	759	6.4
VEHDD333	333	20.00	1200	705	1285	1610	2360	DN80	1106	9.5
VEHDD464	464	27.83	1670	982	1390	1700	2360	DN80	1493	13.4
VEHDD583	583	35.00	2100	1235	1425	2040	2360	DN80	1792	16.2
VEHDD750	750	45.00	2700	1588	1515	2085	2850	DN80	2335	19.9
VEHDD917	917	55.00	3300	1941	1590	2100	2850	DN80	2755	25.4
VEHDD1056	1056	63.33	3800	2235	1600	2390	3100	DN100	3188	29.4
VEHDD1167	1167	70.00	4200	2470	1780	2420	3100	DN100	3600	33
VEHDD1361	1361	81.67	4900	2882	1820	2470	3250	DN150	4060	39.2
VEHDD1556	1556	93.33	5600	3294	1875	2580	3250	DN150	4713	42.4
VEHDD1708	1708	102.50	6150	3617	1895	2630	3250	DN150	5370	46.5
VEHDD1978	1978	118.67	7120	4188	2081	3142	3250	DN150	5895	55.3
VEHDD2217	2217	133.00	7980	4694	2230	3180	3250	DN150	6950	61.9
VEHDD2389	2389	143.33	8600	5058	2285	3240	3400	DN200	7250	68.1
VEHDD2833	2833	170.00	10200	6000	2330	3320	2320	DN200	8445	77

1. Based on -40°C pressure dew point with inlet conditions of 7 barg and 35°C.
Systems with higher flow rates and/or lower pressure dew points are available upon request.

Correction Factors for Sizing of VEHDD Dryers for Different Operating Temperatures and Pressures

Pressure (barg)	Temperature (°C)			
	25	30	35	40
4	0.66	0.64	0.62	0.59
5	0.80	0.77	0.75	0.71
6	0.94	0.90	0.87	0.84
7	1.07	1.03	1.00	0.96
8	1.16	1.14	1.11	1.08
9	1.23	1.21	1.18	1.14
10	1.32	1.30	1.27	1.24

Example:

Flow rate	3000m ³ /h
Pressure	9 bar
Inlet temp	35°C
Pressure dew point	-40°C

Dryer capacity: $3000/1.18 = 2542 \text{ m}^3/\text{h}$
Therefore, selected model
dryer = VEHDD750

Airfilter Engineering reserves the right to change specifications without prior notice. (Rev 03/07/14)



**PT. ARJUNA
SOLUSI SEJAHTERA**

INDONESIA DISTRIBUTOR:

PT. ARJUNA SOLUSI SEJAHTERA

Office: Central Business District, Greenlake City, Ruko CBD Blok C-68. Cipondoh, Tangerang
Warehouse: Mutiara Taman Palem blok A3 no. 21, Jakarta Barat
Phone: 021-22524347
Fax: 021-22524347
Email: ho@arjunasolusi.co.id

