



HEATLESS COMPRESSED AIR ADSORPTION DRYERS

C-HDD-N SERIES

HEATLESS COMPRESSED AIR ADSORPTION DRYERS C-HDD-N SERIES

The Problem

Compressed air is a commonly used power source. Over the years it became a crucial part of a wide range in industrial processes. However, compressed air after compression is not clean and contains impurities like water, oil, dirt, wear particles and so on. This mixture creates a form of condensate which damages downstream equipment like air tools, pneumatic cylinders and other pneumatic equipments. It also causes high product rejects, high maintenance and costly air leaks in compressed air systems. The use of highly efficient compressed air filters and condensate drains will remove a lot of these impurities and can eliminate most of the problems downstream.

For many applications this is not enough. These applications need an even higher level of compressed air quality.

AFE's C-HDD-N desiccant dryers will provide this level of air quality at the point where the quality is needed without investing a large amount in centralized purification systems which are often not needed because only certain areas of the production process need that high quality air.

The Solution

The C-HDD-N Series of compact desiccant air dryers offers users the air quality at the point where it is needed. Utilizing a reliable technology, the C-HDD-N dryers provide the security to run the process without interruption and to have safe and reliable operations of downstream machines and air tools.

This series comes with installed pre- and afterfilter, desiccant fill and a reliable PCB controller with indication lights to monitor the operation. The PCB controller is ready built in and only has to be connected to an electrical power source and compressed air inlet/outlet.

Optionally available is a dryer run/stop dry contact as well as a load control system for energy savings.

This series of compact desiccant air dryers will meet the requirements of ISO 8573.1 Class 1.2.1 as a standard. Higher quality classes based on request are available.

Engineering Solutions to Cleaner Air

How does the AFE C-HDD-N Desiccant Dryer work?

Two vessels connected in parallel are required for the continuous operation of drying via the adsorption process. Each vessel is filled with desiccants which act as the drying medium. AFE desiccant dryers use high performance desiccant which have a long service life at high input temperatures, resulting in very low pressure dew points.

Stage 1: The drying of compressed air takes place in vessel A and simultaneously, desorption (re-generation of the desiccant) occurs in vessel B. The desorption process in vessel B occurs in a counter flow direction by using a small flow of dry compressed air channeled from the outlet of vessel A. The mode of operation of pressure change desorption corresponds to almost isothermal desorption through partial pressure drop in the adsorbing component by means of pure purge gas.

Stage 2: Upon completion of the re-generation cycle, re-pressurization takes place in vessel B until both vessels equalize in pressure. At this stage, the vessels are ready to switch over.

Stage 3: The air from vessel A will purge out and the drying cycle switches to vessel B. Vessel A will now undergo the desorption cycle to re-generate the desiccants.

The entire process will repeat itself to continuously dry the compressed air.

All AFE dryers are installed with coalescing pre-filters and particle after-filters to provide clean and dry compressed air (CDA).

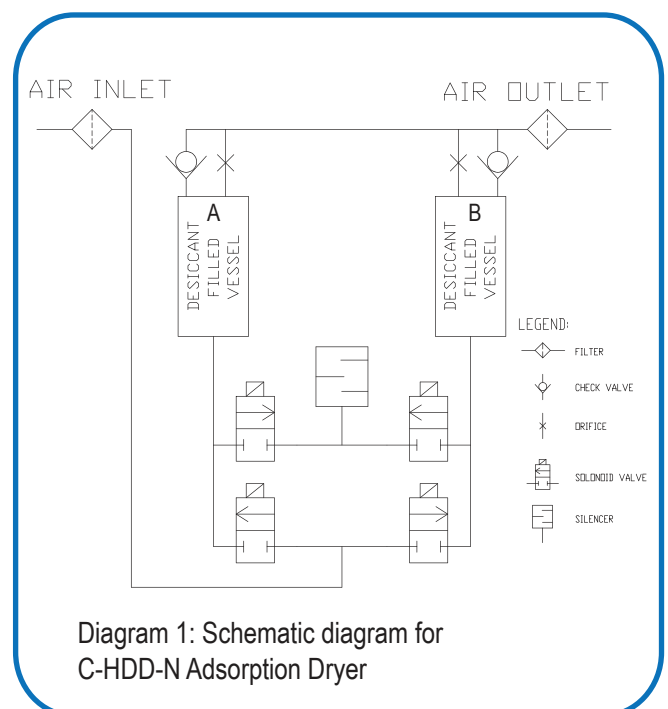

Diagram 1: Schematic diagram for C-HDD-N Adsorption Dryer

AFE manufactured desiccant dryers are fully tested and are produced in accordance to the ISO9001 quality system.



- **Point of use application**
 - Air quality at the point where it's needed.
- **Simple installation**
 - Only air in/air out and power to be connected.
- **Compact design**
 - Specially designed for point of use applications, small footprints.
- **Easy maintenance**
 - Designed for quick parts change with standard components.



CERTIFICATE OF APPROVAL

This is to certify that the Quality Management System of:

Airfilter Engineering (M) Sdn. Bhd. (271956-U)
No. 20, Jalan Anggerik Mokara 31/47
Section 31, Kota Kemuning
40460 Shah Alam, Selangor
Malaysia

has been approved by Lloyd's Register Quality Assurance to the following Quality Management System Standards:

ISO 9001:2008
EN ISO 9001:2008
BS EN ISO 9001:2008
MS ISO 9001:2008

The Quality Management System is applicable to:

Manufacture of products for separation, filtration, adsorption and condensate technology for the industrial treatment of compressed air and industrial gases.

Approval Certificate No: KLR 0403771

Original Approval: 26 March 2002

Current Certificate: 26 March 2014

Certificate Expiry: 25 March 2017

[Signature]

Issued by: Lloyd's Register of Shipping (M) Bhd for and on behalf of Lloyd's Register Quality Assurance Ltd.



Highamford Middlemarsh Office Village, 5 Skin Drive, Coventry, CV3 4FL, United Kingdom
 The approval is granted only in accordance with the scope of approval and certification conditions and is limited to UKAS.
 The use of the UKAS Accreditation Mark requires Accreditation in respect of those activities covered by the Accreditation Certificate Number 001.

Applications

C-HDD-N dryers will benefit users with a demand for clean dry air directly at their application point.

Application examples:



TECHNICAL DATA C-HDD-N SERIES

Model Number	Volume Flow Rate ¹				Dimensions (mm)					Conn.	Weight
	l/s	m ³ /min	m ³ /hr	cfm	H	W1	W2	D1	D2	inch	kg
C-HDD-N002	2.30	0.14	8.20	4.80	420	366	245	226	106	G 1/4"	14
C-HDD-N004	4.40	0.26	15.50	9.11	670	366	245	226	106	G 1/4"	18
C-HDD-N007	7.05	0.42	25.40	14.95	920	366	245	226	106	G 1/4"	24
C-HDD-N010	9.75	0.58	35.10	20.65	1120	366	245	226	106	G 1/4"	28
C-HDD-N015	15.64	0.94	56.30	33.12	992	550	375	273	160	G 1/2"	51
C-HDD-N020	20.00	1.20	72.00	42.35	1242	550	375	273	160	G 1/2"	51
C-HDD-N030	30.00	1.80	108.00	63.50	1036	755	495	338	220	G 1"	93
C-HDD-N045	45.00	2.70	162.00	95.30	1386	755	495	338	220	G 1"	114

1. Based on -40°C pressure dew point with inlet conditions of 7 barg and 35 °C
Systems for lower pressure dew points are available upon request.

Correction Factors for Sizing of C-HDD-N Dryers for Different Operating Temperatures and Pressures

Pressure (barg)	Inlet Temperature (°C)					
	25	30	35	40	45	50
4	0.66	0.64	0.62	0.59	0.55	0.50
5	0.80	0.77	0.75	0.71	0.67	0.63
6	0.94	0.90	0.87	0.84	0.79	0.76
7	1.07	1.03	1.00	0.96	0.92	0.87
8	1.16	1.14	1.11	1.08	1.04	1.00
9	1.23	1.21	1.18	1.14	1.10	1.07
10	1.32	1.30	1.27	1.24	1.20	1.16

Example:

Flow rate	16.9 m ³ /h
Pressure	6 bar
Inlet temp	40°C
Pressure dew point	-40°C

Dryer capacity: $16.9/0.84 = 20.12 \text{ m}^3$

Therefore, selected dryer
model = C-HDD-N 007

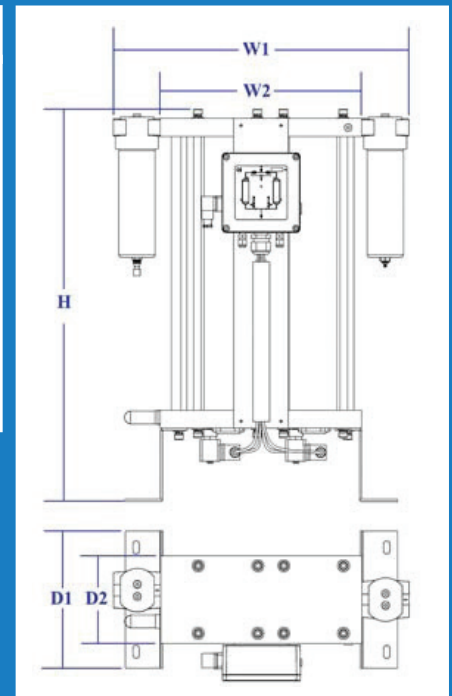

Airfilter Engineering reserves the right to change specifications without prior notice.(V2/05/15)