



**HEATLESS
COMPRESSED
AIR ADSORPTION
DRYERS**
HDD SERIES

HEATLESS COMPRESSED AIR ADSORPTION DRYERS HDD-SERIES

The Simple Philosophy of Heatless Desiccant Dryers for Compressed Air

Drying compressed air through adsorption represents a purely physical process in the course of which water vapour is bound to the drying medium (desiccant) through binding forces of molecular adhesion. For adsorption to take place, moist air is directed through the adsorber at various operating pressures. During this process, the moist compressed air comes into contact with the hydrophilic desiccant molecules when it flows from the bottom to the top of the vessel. The desiccant molecules will retain the moisture which results in dry compressed air leaving the vessel.

AFE HDD Dryer Control Systems for Heatless Desiccant Dryers

AFE offers two control systems for the HDD desiccant dryers:

1. PLC (Programmable Logic Controller System)

The HDD dryer is available with a time based PLC Control as standard. The standard cycle times are 5 minutes of adsorption followed by 4 minutes of regeneration and 1 minute for pressure build up.

2. LCS (Load Control System)

The LCS is a more economical system with energy saving features. Instead of re-generating every 5 minutes in a time controlled PLC system, the LCS uses a dew point sensor which detects the moisture load of the compressed air at the outlet. The system then re-generates only when the dew point is higher than the set level. This saves purge flow and therefore energy.

Engineering
Solutions
to Cleaner Air

How Does AFE HDD Desiccant Dryer Works?

Two vessels connected in parallel are required for the continuous operation of drying via the adsorption process. Each vessel is filled with desiccants which act as the drying medium. AFE desiccant dryers use high performance desiccant which have a long service life at high input temperatures, resulting in very low pressure dew points.

Stage 1: The drying of compressed air takes place in vessel A and simultaneously, desorption (re-generation of the desiccant) occurs in vessel B. The desorption process in vessel B occurs in a counter flow direction by using a small flow of dry compressed air channeled from the outlet of vessel A. The mode of operation of pressure change desorption corresponds to almost isothermal desorption through partial pressure drop in the adsorbing component by means of pure purge gas.

Stage 2: Upon completion of the re-generation cycle, re-pressurization takes place in vessel B until both vessels equalize in pressure. At this stage, the vessels are ready to switch over.

Stage 3: The air from vessel A will purge out and the drying cycle switches to vessel B. Vessel A will now undergo the desorption cycle to re-generate the desiccants.

The entire process will repeat itself to continuously dry the compressed air.

All AFE dryers are installed with coalescing pre-filters and particle after-filters to provide clean and dry compressed air (CDA).

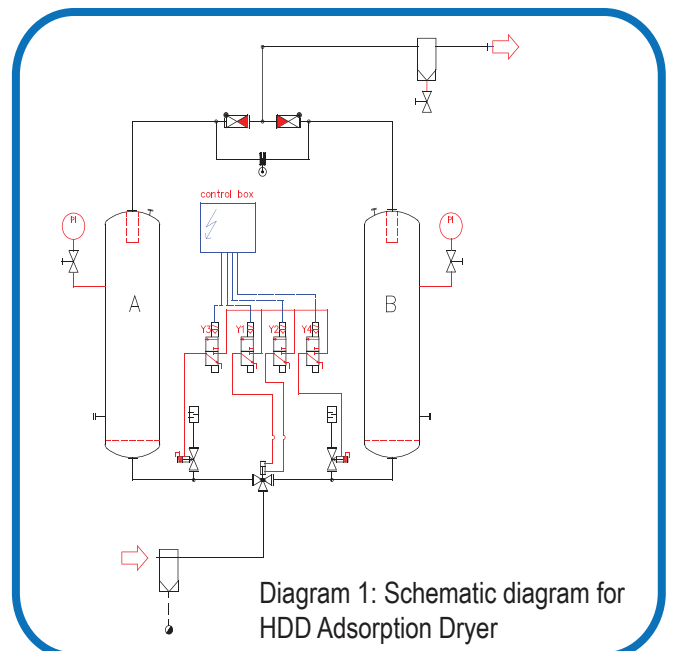

Diagram 1: Schematic diagram for HDD Adsorption Dryer

AFE manufactured desiccant dryers are fully tested and are produced in accordance to the ISO9001 quality system.



Features and Advantages of the HDD Series Dessicant Dryers

- Welded vessels designed according to ASME VIII Div1. Standards. (other designs and approvals on request)
- Usage of self cleaning stainless steel wedge wire in the wet area allows an even distribution of air flow with low differential pressure across the system.
- Indication lights for dryer ON/OFF mode, adsorption, re-generation and LED display available for the dew point (if dew point meter is installed).
- Usage of high performance desiccant which are suitable for application in a wide range of operating conditions.
- Usage of standard industrial valves which are readily available and easily maintained.
- Load Control System (LCS) display available as an economical and energy saving option.
- Customized dryers according to OEMs' requirements are available upon request.



The HDD Series of Desiccant Dryers manufactured by AFE benefit from a simple but effective design which has been studied and improved with many years of experience in the compressed air industry. AFE dryers are manufactured to cater to a wide range of applications and the main benefits are:

- proven technology
- robust construction
- reliable performance
- easy maintenance

HEATLESS COMPRESSED AIR ADSORPTION DRYER HDD-SERIES DATA

HDD SERIES DESICCANT DRYERS - SPECIFICATIONS

Model Number	Volume Flow Rate ¹				Dimensions (mm)			Connection	Weight
	l/s	m ³ /min	m ³ /hr	cfm	A (D)	B (W)	C (H)	inch	kg
HDD0039	39	2.33	140	82	605	960	1915	1"	204
HDD0053	53	3.17	190	111	570	990	1925	1"	274
HDD0067	67	4.00	240	141	570	990	1925	1"	274
HDD0106	106	6.33	380	223	630	990	1965	1"	370
HDD0150	150	9.00	540	317	610	1090	2125	1 ½"	481
HDD0181	181	10.83	650	382	655	1100	2140	1 ½"	553
HDD0236	236	14.67	850	500	650	1245	2180	1 ½"	643
HDD0292	292	17.50	1050	617	700	1320	2240	2"	765
HDD0389	389	23.33	1400	823	735	1510	2130	DN80/3"	956
HDD0472	472	28.33	1700	1000	750	1610	2150	DN80/3"	1136
HDD0569	569	34.17	2050	1206	780	1660	2155	DN80/3"	1272
HDD0667	667	40.00	2400	1412	850	1710	2270	DN80/3"	1404
HDD0778	778	46.67	2800	1647	905	1760	2200	DN80/3"	1547
HDD0889	889	53.33	3200	1882	915	2080	2370	DN100/4"	1739
HDD1028	1028	61.67	3799	2176	970	2155	2410	DN100/4"	1903
HDD1167	1167	70.00	4200	2470	1020	2270	2430	DN100/4"	2074

1. Based on -40°C pressure dew point with inlet conditions of 7 barg and 35°C.
Systems with higher flow rates and/or lower pressure dew points are available upon request.

Correction Factors for Sizing of HDD Dryers for Different Operating Temperatures and Pressures

Pressure (barg)	Temperature (°C)					
	25	30	35	40	45	50
4	0.66	0.64	0.62	0.59	0.55	0.50
5	0.80	0.77	0.75	0.71	0.67	0.63
6	0.94	0.90	0.87	0.84	0.79	0.76
7	1.07	1.03	1.00	0.96	0.92	0.87
8	1.16	1.14	1.11	1.08	1.04	1.00
9	1.23	1.21	1.18	1.14	1.10	1.07
10	1.32	1.30	1.27	1.24	1.20	1.16

Example:

Flow rate	550 m ³ /h
Pressure	9 bar
Inlet temp	35°C
Pressure dew point	-40°C

Dryer capacity: $550/1.18 = 437 \text{ m}^3$
Therefore, selected dryer model = HDD 0150

Airfilter Engineering reserves the right to change specifications without prior notice.(V1/05/15)



**PT. ARJUNA
SOLUSI SEJAHTERA**

INDONESIA DISTRIBUTOR:

PT. ARJUNA SOLUSI SEJAHTERA

Office: Central Business District, Greenlake City, Ruko CBD Blok C-68. Cipondoh, Tangerang

Warehouse: Mutiara Taman Palem blok A3 no. 21, Jakarta Barat

Phone: 021-22524347

Fax: 021-22524347

Email: ho@arjunasolusi.co.id

