



WATER SEPARATORS

Centrifugal separation to remove up to 99%
of water aerosol in compressed air

CSC-SERIES

HOUSINGS SPECIFICATIONS

Description	Housings designed for application in non-aggressive compressed air systems.
Product Compliance To	Malaysia D.O.S.H approval comply to ASME VIII Div.1
Housing Material	Carbon Steel
Maximum Operating Pressure	Standard: 10 bar (145 psi), optional up to 16 bar (232 psi)
External Coating	Epoxy coated
Inlet and Outlet Port	Flanges (BS EN 1092-1)

STANDARD AND OPTIONAL ACCESSORIES

Automatic Drain (Mechanical)	Mechanical float auto-drains (EAD416) (16 bar) and manual drains (50 bar) - Standard
Automatic Drain (Electronic)	Electronic sensor and timer auto-drains (16 bar and 50 Bar max) - Optional

STANDARD FACTORY TEST

For Housing	Hydrostatic Test with water pressure at 1.5 times max operating pressure
-------------	--

WATER SEPARATOR MODEL

Model	Conn. (Inlet & Outlet)	Max. 10 Bar Water Separator (Capacity At 7 Bar g)		Approx. Dimensions, mm				Max. Pressure, (Bar)	Approx. Weight, (Kg)
		m3/min	CFM	A	B	C	D		
CSC28*	DN80	39	1377	460	818	291	145	10	71
CSC36*	DN100	52	1836	460	818	291	145	10	77
CSC50*	DN125	86	3037	550	978	348	145	10	111
CSC60*	DN150	118	4167	570	1088	362	145	10	129
CSC90*	DN200	128	4520	712	1240	399	145	10	205
CSC130*	DN250	188	6639	750	1310	462	145	10	270
CSC170*	DN300	238	8404	894	1438	526	145	10	426

Note: Replace asterisk with relevant product code. E.g.: CSC28-E4-10B

FEATURES AND ADVANTAGES

Removes up to 99% bulk water
Very low maintenance cost
Simple and easy to install
Efficient automatic drain

OPTIONAL DRAIN

			
EAD416	ESD Series	ETD Series	Gate valve

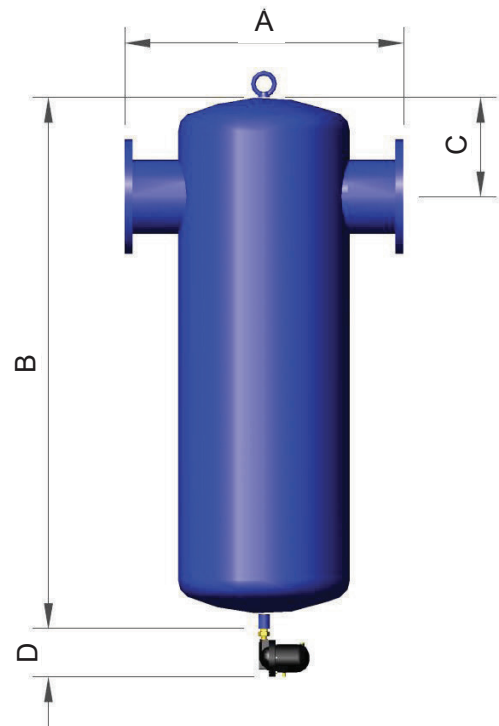

www.airfilterengineering.com

Airfilter Engineering reserves the right to change specifications without prior notice (Rev1.040116)



**PT. ARJUNA
SOLUSI SEJAHTERA**

INDONESIA DISTRIBUTOR:

PT. ARJUNA SOLUSI SEJAHTERA

Office: Central Business District, Greenlake City, Ruko CBD Blok C-68. Cipondoh, Tangerang
Warehouse: Mutiara Taman Palem blok A3 no. 21, Jakarta Barat

Phone: 021-22524347

Fax: 021-22524347

Email: ho@arjunasolusi.co.id

